



# DCA70USI

## MQ POWER Series Generator

### WhisperWatt™

Prime Rating — 56 kW (70 kVA)

Standby Rating — 62 kW (77 kVA)

Three-Phase, 60 Hertz, 0.8 PF

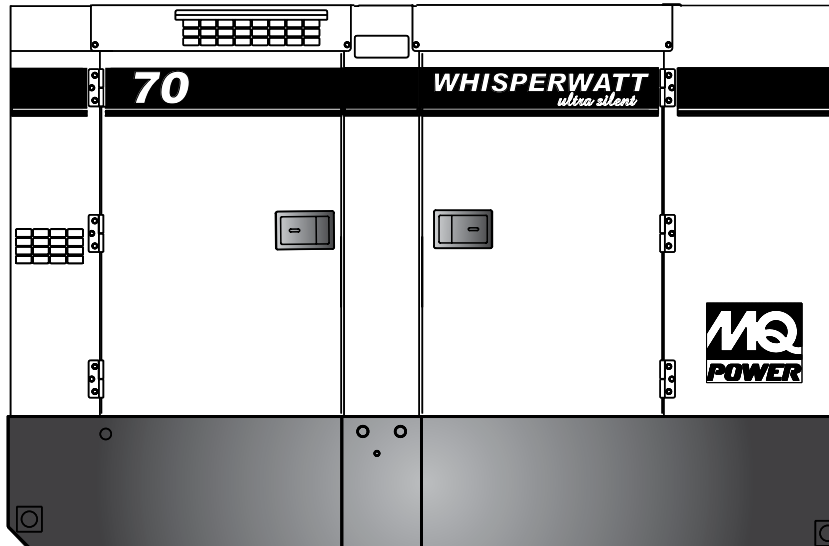

#### STANDARD FEATURES

- Heavy duty, 4-cycle, direct injection, diesel engine provides maximum reliability.
- Brushless alternator reduces service and maintenance requirements and meets temperature rise standards for Class H insulation systems.
- Open delta excitation design provides virtually unlimited excitation for maximum motor starting capability.
- Automatic voltage regulator (AVR) provides precise regulation.
- Electronic Governor Control (Crystal Sync) — maintains frequency to within  $\pm 0.25\%$  from no load to full load.
- Full load acceptance of standby nameplate rating in one step (NFPA 110, para 5-13.2.6).
- Sound attenuated, weather resistant, steel housing provides operation at 60 dB(A) at 23 feet. Fully lockable enclosure allows safe unattended operation.
- Internal fuel tank with direct reading of fuel gauge.
- Seven stage powder coat paint system provides durability and weather protection.
- Fuel/water separator removes condensation from fuel for extended engine life. Panel mounted alarm light included.
- Complete engine analog instrumentation includes DC ammeter, oil pressure gauge, water temp. gauge, fuel level gauge, tachometer/hour meter, preheat indicator, emergency shutdown monitors.
- Automatic start/stop control — automatically starts the generator set during a commercial power failure when used in conjunction with a transfer switch.
- Complete generator analog instrumentation includes voltage regulator control, ammeter phase selector switch, voltmeter phase selector switch, AC voltmeter, AC ammeter, frequency meter, panel light, and circuit breaker.
- Automatic safety shutdown system monitors the water temperature, engine oil pressure, overspeed and overcrank. Warning lights indicate abnormal conditions.
- Complete power panel. Fully covered; three-phase terminals and single phase receptacles allow fast and convenient hookup for most applications including temporary power boxes, tools and lighting equipment. The GFCI receptacles are NEMA 5-20, and the auxiliary outputs use CS6369 twist-lock receptacles.
- Simultaneous single and three phase power.
- Voltage selector switch offers the operator a wide range of voltages that are manually selectable. Fine tuning of the output voltage can be accomplished by adjusting the voltage regulator control knob to obtain the desired voltage.
- EPA emissions certified - Interim Tier 3 emissions compliant.



# DCA70USI

## MQ POWER Series Generator

### SPECIFICATIONS

Generator Specifications		
Design	Revolving field, self-ventilated Drip-proof, single bearing	
Armature Connection	Star with Neutral	Zig Zag
Phase	3	Single
Standby Output	62 KW (77 KVA)	44 KW
Prime Output	56 KW (70 KVA)	40 KW
3Ø Voltage (L-L/L-N) Voltage Selector Switch at 3Ø 240/139	208Y/120, 220Y/127, 240Y/139	N/A
3Ø Voltage (L-L/L-N) Voltage Selector Switch at 3Ø 480/277	416Y/240, 440Y/254, 480Y/277	N/A
1Ø Voltage (L-L/L-N) (Voltage Selector Switch at 1Ø 240/120)	N/A	240/120
Power Factor	0.8	1.0
Voltage Regulation (No load to full load)	±0.5%	
Generator RPM	1800	
Frequency	60 Hz	
No. of Poles	4	
Excitation	Brushless with AVR	
Frequency	60 Hz	
Frequency Regulation: No Load to Full Load	Isochronous under varying loads from no load to 100% rated load	
Frequency Regulation: Steady State	±0.25% of mean value for constant loads from no load to full load.	
Insulation	Class H	
Sound Level dB(A) Full load at 23 feet	68	

Engine Specifications	
Make / Model	Isuzu / BJ-4JJ1X
Emissions	EPA Interim Tier 3 Certified
Starting System	Electric
Design	4-cycle, water cooled, direct injection, turbocharged
Displacement	183.0 in <sup>3</sup> (2999 cc)
No. cylinders	4
Bore x Stroke (mm)	95.4 x 104.9
Gross Engine Power Output	97.9 bhp (50 kW)
BMEP	204 psi (1409 kPa)
Piston Speed	1237 ft./min. (6.29 m/s)
Compression Ratio	17.5:1
Engine Speed	1800 rpm
Overspeed Limit	2100 rpm
Oil Capacity	3.96 gallons (15 liters)
Battery	12V 72Ah x 1

Fuel System		
Recommended Fuel	ASTM-D975-No.1 & No.2-D	
Maximum Fuel Flow (per hour)	16 gallons (61 liters)	
Maximum Inlet Restriction (Hg)	5.9 in. (150 mm)	
Fuel Tank Capacity	103 gallons (390 liters)	
<b>Fuel Consumption</b>	<b>gph</b>	<b>lph</b>
At full load	4.1	15.4
At 3/4 load	3.1	11.9
At 1/2 load	2.1	8.1
At 1/4 load	1.3	4.8

Cooling System	
Fan Load	0.4 hp (0.3 kW)
Coolant Capacity (with radiator)	3.57 gallons (13.5 liters)
Coolant Flow Rate (per minute)	15.4 gallons (58.5 liters)
Heat Rejection to Coolant (per minute)	2260 Btu (2.38 MJ)
Heat Rejection to Room (per minute)	578 Btu (0.61 MJ)
Maximum Coolant Friction Head	6.1 psi (42 kPa)
Maximum Coolant Static Head	21 feet (6.4 meters)
Ambient Temperature Rating	104°F (40°C)

Air	
Combustion Air	138 cfm (3.9 m <sup>3</sup> /min)
Maximum Air Cleaner Restriction	25 in. H <sub>2</sub> O (6.25 kPa)
Alternator Cooling Air	526 cfm (14.9 m <sup>3</sup> /min)
Radiator Cooling Air	2009 cfm (56.9 m <sup>3</sup> /min)

Exhaust System	
Gas Flow (full load)	332 cfm (9.4 m <sup>3</sup> /min)
Gas Temperature	932°F (500°C)
Maximum Back Pressure	53.2 in. H <sub>2</sub> O (13.3 kPa)

Amperage	
Rated Voltage	Maximum Amps
1Ø 120 Volt	155.4 Amps (4 wire) 168A x 2 (Zigzag)
1Ø 240 Volt	77.8 Amps (4 wire) 168A (Zigzag)
3Ø 240 Volt	168 Amps
3Ø 480 Volt	84 Amps
Main Line Circuit Breaker Rating	175 Amps
Over Current Relay Trip Set Point 480V Mode Only	84 Amps

### WARRANTY\*

#### Isuzu Engine

12 months from date of purchase with unlimited hours or 24 months from date of purchase with 2000 hours (whichever comes first).

#### Generator

24 months from date of purchase or 2000 hours (whichever occurs first).

#### Trailer

12 months excluding normal wear items.

\*Refer to the express written, one-year limited warranty sheet for additional information.

### NOTICE

Generator is not intended for use in enclosed areas or where free flow of air is restricted.

Backfeed to a utility system can cause electrocution, shock and/or property damage. **DO NOT** connect to any building's electrical system except through an approved device.

Specifications are subject to change without notice.



# DCA70USI

## MQ POWER Series Generator

### MQ POWER DECIBEL LEVELS

Our soundproof housing allows substantially lower operating noise levels than competitive designs. Ultra-Silent are at home on construction sites, in residential neighborhoods, and at hospitals — just about anywhere.

- 90 — Subway / truck traffic
- 80 — Average city traffic
- 70 — Inside car at 60 mph
- 60 — Air conditioner at 20 feet  
**Ultra-Silent at 23 feet**
- 50 — Normal conversation



### ULTRA-SILENT FEATURES

- **Low Noise Muffler** — Large capacity low noise muffler minimizes exhaust sound.
- **Soundproof Casing** — The new design divides the cabinet into three sections, separating the engine, muffler and radiator for more efficient cooling and reduces noise from the engine and fans.
- **New Cooling System** — An advanced design uses two separate air intake systems to cool the generator. The engine fan draws air in to cool the engine and generator housing while a second electric fan directly cools the radiator. With less air being drawn into the generator through each fan, considerably less noise is produced through the top of the generator.
- **Environmental Design** — Constructed using an integrated environmental skid and fuel tank. This design fully contains fuel leakage and any liquid that might leak from the engine such as lube oil or radiator coolant. All potentially hazardous liquids are contained without contaminating the surrounding area.

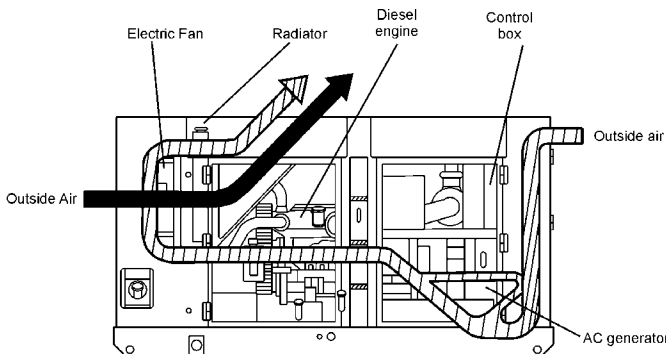

Flow of Cooling Air

### GENERATOR OUTPUT PANEL

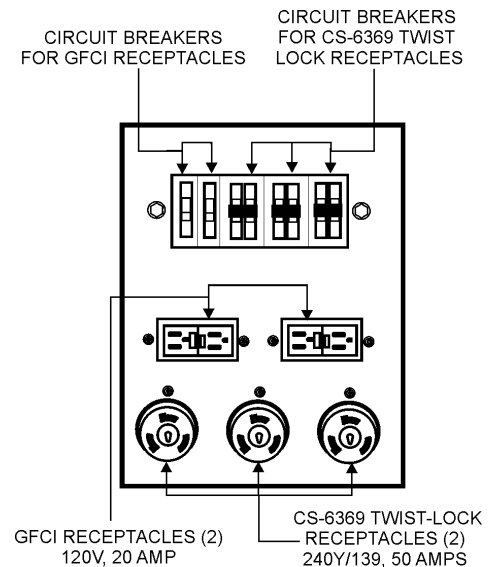

### OPTIONAL CONTROL FEATURES

- **Emergency Stop Switch** — when manually activated shuts down generator in the event of an emergency.
- **Audible alarm** — alerts operator of abnormal conditions.

### OPTIONAL GENERATOR FEATURES

- **Electronic Governor Control (Crystal Sync)** — maintains frequency to within  $\pm 0.25\%$  from no load to full load.
- **Battery Charger** — provides fully automatic and self-adjusting charging to the generator's battery system.
- **Jacket Water Heater** — for easy starting in cold weather climates.
- **Special Batteries** — long life batteries provide extra engine cranking power.
- **Spring Isolators** — provides extra vibration protection for standby applications.
- **Low Coolant Level Shutdown** — provides protection from critically low coolant levels. Includes control panel warning light.
- **Trailer Mounted Package** — meets National Highway Traffic Safety Administration (NHTSA) regulations. Trailer is equipped with electronic or surge brakes with tandem axle configuration.

### OPTIONAL OUTPUT CONNECTIONS

- **Cam-Lok Connectors** — provides quick disconnect alternative to bolt-on connectors.
- **Pin and Sleeve Connectors** — provides industry standard connectors for all voltage requirements.
- **Output Cable** — available in any custom length and size configuration.



# DCA70USI

## MQ POWER Series Generator

### DIMENSIONS

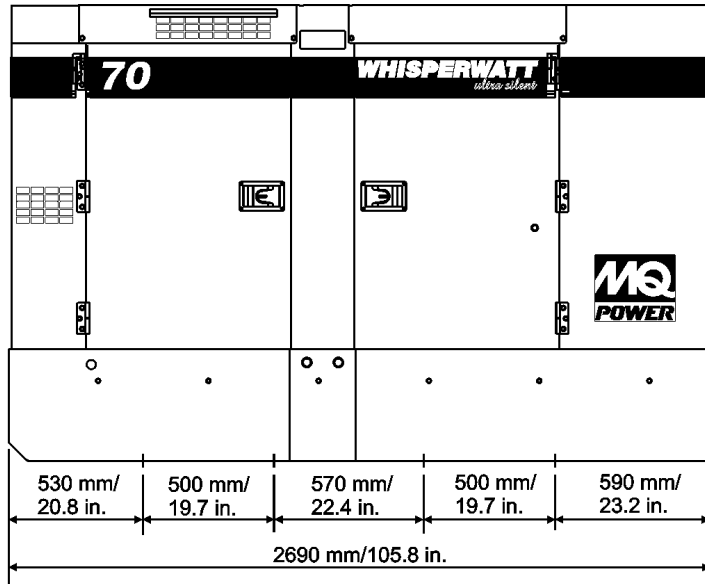
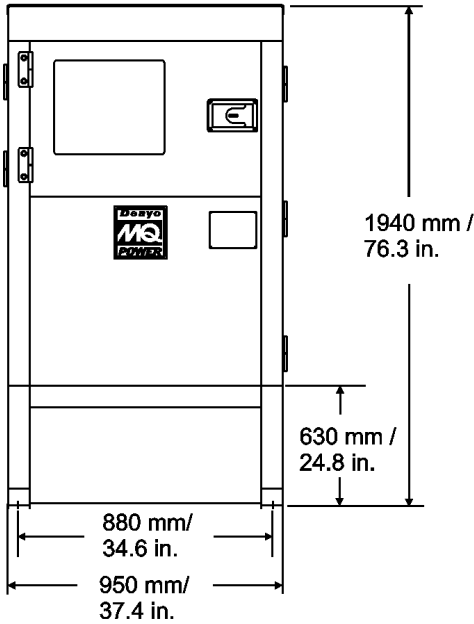

Weight	
Dry Weight	3,771 lbs. (1,710 kg)
Wet Weight	4,553 lbs. (2,065 kg)
Max. Lifting Point Capacity	14,050 lbs. (6,370 kg)

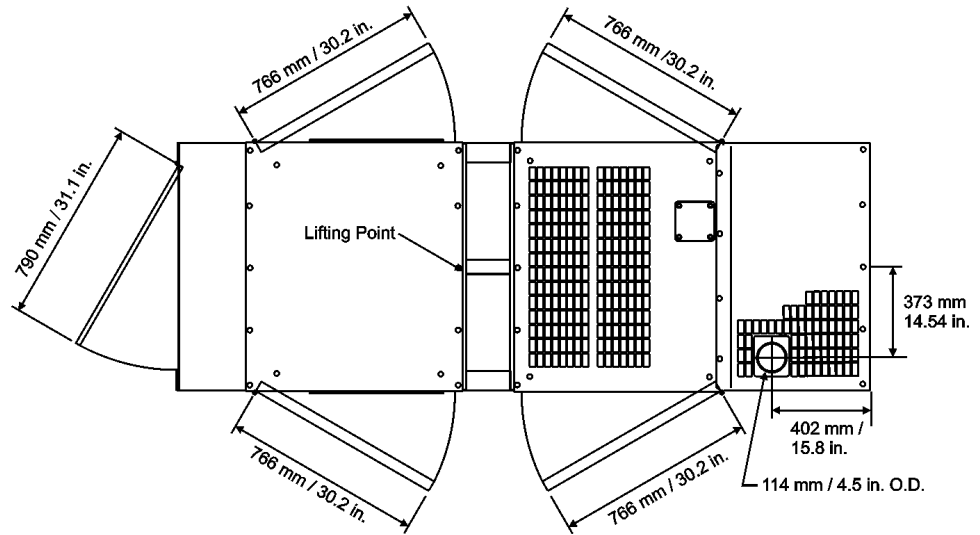

Generator can be placed on a  
MQ Power Model TRLR70XF  
Tandem Axle Trailer

Manufactured by Denyo Co.

Your Multiquip dealer is:

